

CENTRAL MACHINERY

®

8" DRILL PRESS

Model 44505

SET UP AND OPERATING INSTRUCTIONS



Visit our website at: <http://www.harborfreight.com>



**Read this material before using this product.
Failure to do so can result in serious injury.
SAVE THIS MANUAL.**

Copyright© 2010 by Harbor Freight Tools®. All rights reserved. No portion of this manual or any artwork contained herein may be reproduced in any shape or form without the express written consent of Harbor Freight Tools. Diagrams within this manual may not be drawn proportionally. Due to continuing improvements, actual product may differ slightly from the product described herein. Tools required for assembly and service may not be included.

For technical questions or replacement parts, please call 1-800-444-3353.

CONTENTS

IMPORTANT SAFETY INFORMATION	3	MAINTENANCE AND SERVICING... 12	
GENERAL TOOL SAFETY WARNINGS. 3		CLEANING, MAINTENANCE, AND LUBRICATION	12
GROUNDING INSTRUCTIONS	5	TROUBLESHOOTING.....	14
110-120 V~ GROUNDED TOOLS: TOOLS WITH THREE PRONG PLUGS5		PARTS LISTS AND DIAGRAMS	15
DRILL PRESS SAFETY WARNINGS	5	HEAD ASSEMBLY PARTS LIST.....	15
SPECIFICATIONS.....	8	HEAD ASSEMBLY DIAGRAM	16
UNPACKING	8	PARTS LIST AND DIAGRAM A - PULLEY AND SPINDLE	17
INSTRUCTIONS FOR PUTTING INTO USE	8	PARTS LIST AND DIAGRAM B - CHUCK AND SPINDLE SHAFT	18
ASSEMBLY/MOUNTING.....	8	PARTS LIST AND DIAGRAM C - BASE AND TABLE	19
OPERATING INSTRUCTIONS	10	LIMITED 90 DAY WARRANTY	20
TOOL SET UP	10		
WORK PIECE AND WORK AREA SET UP	10		
GENERAL OPERATING INSTRUCTIONS	11		

SAVE THIS MANUAL

Keep this manual for the safety warnings and precautions, assembly, operating, inspection, maintenance and cleaning procedures. Write the product's serial number in the back of the manual near the assembly diagram (or month and year of purchase if product has no number). Keep this manual and the receipt in a safe and dry place for future reference.

IMPORTANT SAFETY INFORMATION

In this manual, on the labeling, and all other information provided with this product:



This is the safety alert symbol. It is used to alert you to potential personal injury hazards. Obey all safety messages that follow this symbol to avoid possible injury or death.

DANGER

DANGER indicates a hazardous situation which, if not avoided, will result in death or serious injury.

WARNING

WARNING indicates a hazardous situation which, if not avoided, could result in death or serious injury.

CAUTION

CAUTION, used with the safety alert symbol, indicates a hazardous situation which, if not avoided, could result in minor or moderate injury.

NOTICE

NOTICE is used to address practices not related to personal injury.

CAUTION

CAUTION, without the safety alert symbol, is used to address practices not related to personal injury.

General Tool Safety Warnings



WARNING Read all safety warnings and instructions. Failure to follow the warnings and instructions may result in electric shock, fire and/or serious injury.

Save all warnings and instructions for future reference.

1. KEEP GUARDS IN PLACE and in working order.
2. REMOVE ADJUSTING KEYS AND WRENCHES. Form habit of checking to see that keys and adjusting wrenches are removed from tool before turning it on.
3. KEEP WORK AREA CLEAN. Cluttered areas and benches invite accidents.
4. DON'T USE IN DANGEROUS ENVIRONMENT. Don't use power tools in damp or wet locations, or expose them to rain. Keep work area well lighted.
5. KEEP CHILDREN AWAY. All visitors should be kept safe distance from work area.
6. MAKE WORKSHOP KID PROOF with padlocks, master switches, or by removing starter keys.
7. DON'T FORCE TOOL. It will do the job better and safer at the rate for which it was designed.

8. **USE RIGHT TOOL.** Don't force tool or attachment to do a job for which it was not designed.

RECOMMENDED MINIMUM WIRE GAUGE FOR EXTENSION CORDS (120 VOLT)				
NAMEPLATE AMPERES (at full load)	EXTENSION CORD LENGTH			
	25'	50'	100'	150'
0 – 6	18	16	16	14
6.1 – 10	18	16	14	12
10.1 – 12	16	16	14	12
12.1 – 16	14	12	Do not use.	

TABLE A

9. **USE PROPER EXTENSION CORD.** Make sure your extension cord is in good condition. When using an extension cord, be sure to use one heavy enough to carry the current your product will draw. An undersized cord will cause a drop in line voltage resulting in loss of power and overheating. Table A shows the correct size to use depending on cord length and nameplate ampere rating. If in doubt, use the next heavier gauge. The smaller the gauge number, the heavier the cord.
10. **WEAR PROPER APPAREL.** Do not wear loose clothing, gloves, neckties, rings, bracelets, or other jewelry which may get caught in moving parts. Nonslip footwear is recommended. Wear protective hair covering to contain long hair.
11. **ALWAYS USE SAFETY GLASSES.** Also use face or dust mask if cutting operation is dusty. Everyday eyeglasses only have impact resistant lenses, they are NOT safety glasses.
12. **SECURE WORK.** Use clamps or a vise to hold work when practical. It's safer than using your hand and it frees both hands to operate tool.

13. **DON'T OVERREACH.** Keep proper footing and balance at all times.
14. **MAINTAIN TOOLS WITH CARE.** Keep tools sharp and clean for best and safest performance. Follow instructions for lubricating and changing accessories.
15. **DISCONNECT TOOLS** before servicing; when changing accessories, such as blades, bits, cutters, and the like.
16. **REDUCE THE RISK OF UNINTENTIONAL STARTING.** Make sure switch is in off position before plugging in.
17. **USE RECOMMENDED ACCESSORIES.** Consult the owner's manual for recommended accessories. The use of improper accessories may cause risk of injury to persons.
18. **NEVER STAND ON TOOL.** Serious injury could occur if the tool is tipped or if the cutting tool is unintentionally contacted.
19. **CHECK DAMAGED PARTS.** Before further use of the tool, a guard or other part that is damaged should be carefully checked to determine that it will operate properly and perform its intended function – check for alignment of moving parts, binding of moving parts, breakage of parts, mounting, and any other conditions that may affect its operation. A guard or other part that is damaged should be properly repaired or replaced.
20. **DIRECTION OF FEED.** Feed work into a blade or cutter against the direction of rotation of the blade or cutter only.
21. **NEVER LEAVE TOOL RUNNING UNATTENDED. TURN POWER OFF.** Don't leave tool until it comes to a complete stop.

GROUNDING INSTRUCTIONS

⚠ WARNING TO PREVENT ELECTRIC SHOCK AND DEATH FROM INCORRECT GROUNDING WIRE CONNECTION READ AND FOLLOW THESE INSTRUCTIONS:



110-120 V~ Grounded Tools: Tools with Three Prong Plugs

1. In the event of a malfunction or breakdown, grounding provides a path of least resistance for electric current to reduce the risk of electric shock. This tool is equipped with an electric cord having an equipment-grounding conductor and a grounding plug. The plug must be plugged into a matching outlet that is properly installed and grounded in accordance with all local codes and ordinances.
2. Do not modify the plug provided – if it will not fit the outlet, have the proper outlet installed by a qualified electrician.
3. Improper connection of the equipment-grounding conductor can result in a risk of electric shock. The conductor with insulation having an outer surface that is green with or without yellow stripes is the equipment-grounding conductor. If repair or replacement of the electric cord or plug is necessary, do not connect the equipment-grounding conductor to a live terminal.
4. Check with a qualified electrician or service personnel if the grounding instructions are not completely understood, or if in doubt as to whether the tool is properly grounded.
5. Use only 3-wire extension cords that have 3-prong grounding plugs and

3-pole receptacles that accept the tool's plug.

6. Repair or replace damaged or worn cord immediately.

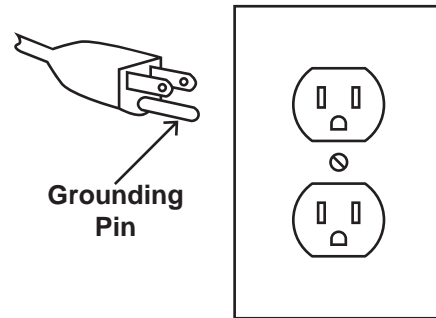

125 V~ 3-Prong Plug and Outlet
(for up to 125 V~ and up to 15 A)

7. This tool is intended for use on a circuit that has an outlet that looks like the one illustrated above in **125 V~ 3-Prong Plug and Outlet**. The tool has a grounding plug that looks like the plug illustrated above in **125 V~ 3-Prong Plug and Outlet**.
8. The outlet must be properly installed and grounded in accordance with all codes and ordinances.
9. Do not use an adapter to connect this tool to a different outlet.

Drill Press Safety Warnings

For Your Own Safety Read Instruction Manual Before Operating Drill Press

1. Wear eye protection.
2. Do not wear gloves, necktie, or loose clothing.
3. Clamp workpiece or brace against column to prevent rotation.
4. Use recommended speed for drill accessory and workpiece material.

5. **DO NOT OPERATE WITH ANY GUARD DISABLED, DAMAGED, OR REMOVED.**
6. The use of accessories or attachments not recommended by the manufacturer may result in a risk of injury to persons.
7. When servicing use only identical replacement parts.
8. Only use safety equipment that has been approved by an appropriate standards agency. Unapproved safety equipment may not provide adequate protection. Eye protection must be ANSI-approved and breathing protection must be NIOSH-approved for the specific hazards in the work area.
9. Industrial applications must follow OSHA guidelines.
10. Maintain labels and nameplates on the tool. These carry important safety information. If unreadable or missing, contact Harbor Freight Tools for a replacement.
11. Avoid unintentional starting. Prepare to begin work before turning on the tool.
12. People with pacemakers should consult their physician(s) before use. Electromagnetic fields in close proximity to heart pacemaker could cause pacemaker interference or pacemaker failure.
13. **WARNING:** Some dust created by power sanding, sawing, grinding, drilling, and other construction activities, contains chemicals known [to the State of California] to cause cancer, birth defects or other reproductive harm. Some examples of these chemicals are:
 - Lead from lead-based paints
 - Crystalline silica from bricks and cement or other masonry products
 - Arsenic and chromium from chemically treated lumber
 Your risk from these exposures varies, depending on how often you do this type of work. To reduce your exposure to these chemicals: work in a well ventilated area, and work with approved safety equipment, such as those dust masks that are specially designed to filter out microscopic particles. (California Health & Safety Code § 25249.5, *et seq.*)
14. **WARNING:** Handling the cord on this product will expose you to lead, a chemical known to the State of California to cause cancer, and birth defects or other reproductive harm. Wash hands after handling. (California Health & Safety Code § 25249.5, *et seq.*)
15. The warnings, precautions, and instructions discussed in this instruction manual cannot cover all possible conditions and situations that may occur. It must be understood by the operator that common sense and caution are factors which cannot be built into this product, but must be supplied by the operator.

Vibration Safety

This tool vibrates during use. Repeated or long-term exposure to vibration may cause temporary or permanent physical injury, particularly to the hands, arms and shoulders. To reduce the risk of vibration-related injury:

1. Anyone using vibrating tools regularly or for an extended period should first be examined by a doctor and then have regular medical check-ups to ensure medical problems are not being caused or worsened from use. Pregnant women or people who have impaired blood circulation to the hand, past hand injuries, nervous system disorders,

diabetes, or Raynaud's Disease should not use this tool. If you feel any medical or physical symptoms related to vibration (such as tingling, numbness, and white or blue fingers), seek medical advice as soon as possible.

2. Do not smoke during use. Nicotine reduces the blood supply to the hands and fingers, increasing the risk of vibration-related injury.
3. Wear suitable gloves to reduce the vibration effects on the user.
4. Use tools with the lowest vibration when there is a choice between different processes.
5. Include vibration-free periods each day of work.
6. Grip tool as lightly as possible (while still keeping safe control of it). Let the tool do the work.
7. To reduce vibration, maintain the tool as explained in this manual. If any abnormal vibration occurs, stop use immediately.



**SAVE THESE
INSTRUCTIONS.**

SPECIFICATIONS

Electrical Input	120 V~, 60 Hz, 1/3 HP (3.6 A)
Motor Speed	1750 RPM (No Load)
Spindle Speeds	620, 1100, 1720, 2340, and 3100 RPM
Spindle Stroke	2"
Base	11-1/8" x 6-3/8"; Slot: 9/16"
Throat Depth	4" (of 8" swing)
Chuck	1/2", keyless
Table Rotation	360°; Tilt: 45° (left and right)
Table Size	6-5/8" x 6-3/8"
Table Slot	5/8"



UNPACKING

When unpacking, make sure that the item is intact and undamaged. If any parts are missing or broken, please call Harbor Freight Tools at 1-800-444-3353 as soon as possible.

Assembly hardware is located in separate bags/boxes. Each contains the necessary parts for each assembly step. Remove all packing and protective material from the Drill Press components.

INSTRUCTIONS FOR PUTTING INTO USE



Read the **ENTIRE IMPORTANT SAFETY INFORMATION** section at the beginning of this manual including all text under subheadings therein before set up or use of this product.

⚠️ WARNING

TO PREVENT SERIOUS INJURY

FROM ACCIDENTAL OPERATION:

Turn the Power Switch of the tool to its "OFF" position and unplug the tool from its electrical outlet before assembling or making any adjustments to the tool.

Note: For additional information regarding the parts listed in the following pages, refer to the Assembly Diagram near the end of this manual.

Assembly/Mounting

Note: Assembly hardware is located in separate bags/boxes.

1. Position the **Base (C4)** on a level and sturdy table for mounting. It is recommended to bolt the Base to the table using appropriate hardware (not supplied).
2. Place the **Support Tube (C3)** on the Base, aligning the mounting holes.
3. Insert three large Hex Screws (C5) into the mounting holes and tighten.
4. Install the **Table Support (C1)**, with attached Table (C7), over the Support Tube (C3) and slide it down. Hand tighten the Lock Handle Support (C2).

CAUTION! Avoid injuries. The next step involves lifting the Head Assembly onto the Support Tube. The Head Assembly is heavy. Have someone help you lift this assembly into place.



5. Using two people, lift the **Head (1) Assembly** up and onto the Support Tube (C3). Slide it down on the Column Tube as far as it will go. Align it so that it faces straight forward, inline with the Base.

6. Thread in two Set Screws (11), into the side of the Head (1) and tighten.
7. Attach Knob (A2) to the (top) pulley Guard (A5) using Pan Head Screw (A3).
8. Adjust **Belt (A4)** tension:
 - a. Open the pulley Guard (A5) to expose the Belt.
 - b. Turn the Motor Adjusting Knob (10) counterclockwise to loosen Belt Tension.
 - c. Push the Motor backward, tightening the Belt on the pulleys, and hold in place.
 - d. Turn the Motor Adjusting Knob clockwise to tighten the Belt in place.
 - e. Refer to the chart inside the Guard lid to select speed and belt locations.

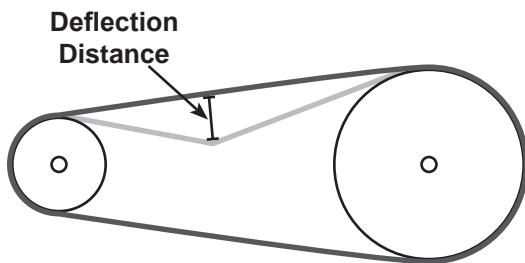

Note: To test the proper belt tension, push in on the center of each belt at its center. It should move only 1/2 inch (in or out).

CAUTION! Overtightening the belts can cause the motor to bind, and not start. It can also damage Motor bearings.

9. Thread the **Feed Knobs (12)** and **Rods (13)** onto the Pinion Shaft (14) and tighten them.
10. Install the **Chuck (B8)**:
 - a. Thoroughly clean the tapered hole in the Chuck and the Spindle Shaft (B7) of all dirt, grease, oil, and protective coatings (paint thinner may be necessary).
 - b. Slide the Chuck onto the Spindle Shaft.
 - c. Turn the Chuck sleeve clockwise and open the jaws completely.

- d. Tap the nose of the Chuck lightly with a piece of wood to securely set the Chuck.



11. Verify that the Table (C7) is square (90 degrees) to the Head Assembly and drill bit.
 - a. Secure a three inch drill bit in the Chuck (hand tighten, no chuck key is required).
 - b. Raise the Table to within four inches of the Chuck.
 - c. Place the long side of a combination square on the Table.
 - d. Align the short side of the square to the drill bit.
 - e. If the Table is not square to the bit, loosen Screw (C6) with a wrench.
 - f. Rotate the Table until it is square to the bit.
 - g. Retighten the Screw (C6).
12. Install Light Bulb:

Install light bulb (not more than 5W) into socket, then install and tighten the socket cover clockwise.

OPERATING INSTRUCTIONS



Read the **ENTIRE IMPORTANT SAFETY INFORMATION** section at the beginning of this manual including all text under subheadings therein before set up or use of this product.

Tool Set Up

⚠️ WARNING TO PREVENT SERIOUS INJURY

FROM ACCIDENTAL OPERATION:

Turn the Power Switch of the tool to its “OFF” position and unplug the tool from its electrical outlet before performing any inspection, maintenance, or cleaning procedures.

TO PREVENT SERIOUS INJURY: DO NOT OPERATE WITH ANY GUARD DISABLED, DAMAGED, OR REMOVED.

Setting the Depth Scale to Drill to a Specified Depth

1. Make sure the Drill Press is OFF and Power Cord (33) is unplugged. Secure the workpiece to the Table.

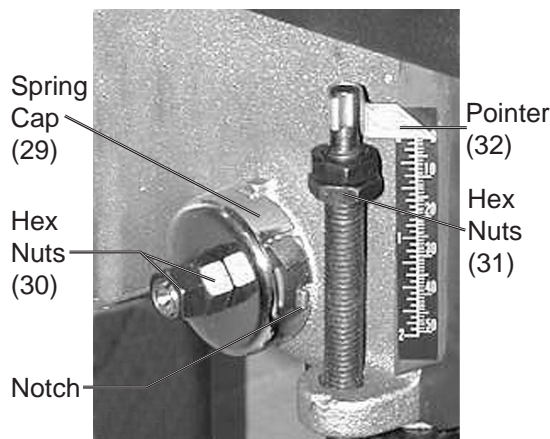

2. Mark the desired hole depth on the side of the workpiece. Also view the depth indicator Pointer (32).
3. Loosen the Hex Nuts (31) and screw both toward the top of Stop Rod (B12).
4. Turn the Feed Wheel counterclockwise to bring the tip of the drill bit down, next to the hole depth mark.

5. Turn the Hex Nuts (31) down until they touch the Feed Wheel stop.

Tilting the Table

1. Loosen Screw (C6) under the Table assembly with a wrench.
2. Rotate the Table to the desired angle. The scale can be used to approximate the angle.
3. Retighten the Screw.

Work Piece and Work Area Set Up

1. Designate a work area that is clean and well-lit. The work area must not allow access by children or pets to prevent distraction and injury.
2. Route the power cord along a safe route to reach the work area without creating a tripping hazard or exposing the power cord to possible damage. The power cord must reach the work area with enough extra length to allow free movement while working.
3. Clamp workpiece or brace against column to prevent rotation.
4. There must not be objects, such as utility lines, nearby that will present a hazard while working.

General Operating Instructions

1. Secure the tool to a supporting structure before use.
2. Make sure the Drill Press is OFF and the Power Cord (33) is unplugged. Loosen the Lock Handle Support (C2) and adjust the Table height to accommodate the workpiece being drilled. Retighten Lock Support Handle.

3. Open the Chuck (B8) and insert the drill bit in the center.
Hand tighten the Chuck securely.
4. Secure the workpiece (and backup material) to the Table using a vise and/or clamp.
The workpiece sits on the backup material which is typically a scrap piece of wood used to stabilize the workpiece. It also helps the drill make a cleaner hole. To keep it from spinning, have it touching the left side of the Column.
5. Bring the drill bit down with the Feed Knob (12) to where the hole is to be drilled.
Make minor workpiece alignment adjustments.
6. Plug the Power Cord (33) into an electrical outlet.
7. Insert the Switch Key (24) into the Locking Switch (21).

Warning: Wear an ANSI-approved full face shield while drilling.

8. Push the Switch up to turn the Motor ON.
9. Pull down on the Feed Knob and slowly drill the hole into the workpiece.

Warning: If the drill bit grabs and spins the workpiece, do not attempt to stop the spinning with your hands. Step back, and push the Switch down to the OFF position. Wait for the spindle to stop turning before dislodging the workpiece.

10. When the drilling is complete, press the Switch to the OFF position and remove the Switch Key (Keep the Switch Key in a safe place).
11. To prevent accidents, turn off the tool and disconnect its power supply after use.

MAINTENANCE AND SERVICING



Procedures not specifically explained in this manual must be performed only by a qualified technician.

!WARNING

TO PREVENT SERIOUS INJURY

FROM ACCIDENTAL OPERATION:

Turn the Power Switch of the tool to its “OFF” position and unplug the tool from its electrical outlet before performing any inspection, maintenance, or cleaning procedures.

TO PREVENT SERIOUS INJURY FROM TOOL FAILURE:

Do not use damaged equipment. If abnormal noise or vibration occurs, have the problem corrected before further use.

Cleaning, Maintenance, and Lubrication

1. **BEFORE EACH USE**, inspect the general condition of the tool. Check for loose hardware, misalignment or binding of moving parts, cracked or broken parts, damaged electrical wiring, and any other condition that may affect its safe operation.
2. **AFTER USE**, wipe external surfaces of the tool with clean cloth.
3. **!WARNING!** If the supply cord of this power tool is damaged, it must be replaced only by a qualified service technician.

Removing the Chuck and Spindle Shaft

During this procedure, refer to the Chuck and Spindle Assembly Drawing.

1. Pull the Feed Wheel counterclockwise and hold the Chuck at a depth of three inches.
2. Align the key holes in the Spindle Shaft (B7) and the Quill Tube (B3) by turning the Chuck by hand.
3. Insert a Wedge Drift Key (not supplied) into the key holes.
4. Place a bundled cloth or basket below the Chuck to catch it when it falls. Lightly tap the Wedge Drift Key with a rubber mallet until the Spindle Shaft falls out of the Quill Tube.

Installing the Chuck and Spindle Shaft

1. Using a clean cloth, wipe the tapered surfaces on the Spindle Shaft (B7).
2. Slide the Spindle Shaft and Chuck assembly up and into the Quill Tube (B3).
At the same time, turn the assembly until the rectangular end of the Spindle Shaft slips into the notch on the Quill Tube.

!WARNING! In the previous step, if the Spindle Shaft is not properly set in the Quill Tube notch, it may fly out during operation.

3. Loosen the Lock Handle Support (C2) and raise the Table (C7) about three inches below the Chuck.
4. Turn the Chuck sleeve clockwise to open the jaws completely.
5. Pull the Feed Knob counterclockwise and force the Chuck against the Table until the Spindle Shaft is secure.

Adjusting the Feed Wheel Return Tension Spring

CAUTION! Wear an ANSI-approved full face shield during this procedure.

1. Move the Chuck to its uppermost position.
2. Loosen Hex Nuts (31) and move both to the lowermost position. This will keep the Chuck from falling during this adjustment.
3. Insert a screwdriver in the lower-front notch of the Spring Cap (29). Hold it in place and, using a wrench, remove the (outer) Hex Nut (30) only.
4. With the screwdriver still in place, loosen the (inner) Hex Nut (30) until the Spring Cap notch disengages from the Spring Retainer (27) -- about 1/8 inch.
8. Pull the Feed Knob and check the spring tension, making sure the up movement is smooth and complete. From one inch down, the Chuck should return to its uppermost position. If more tension is required, repeat steps.
9. Replace the (outer) Hex Nut and tighten on top of the (inner) Hex Nut. Do not overtighten.
10. If the (up/down) movement is restricted, slightly loosen the (inner) Hex Nut, and retighten the (outer) Hex Nut.

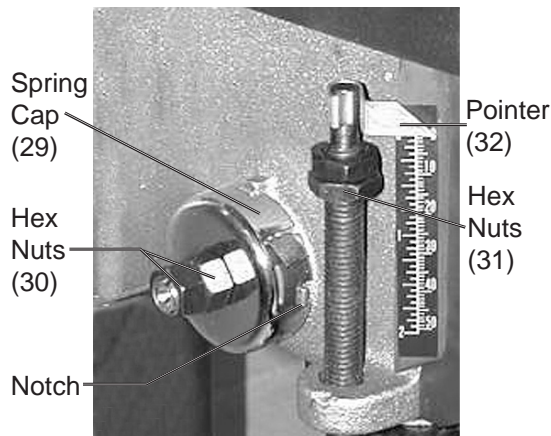

5. Turn the screwdriver counterclockwise and engage the next Spring Cap notch. Leave the screwdriver in place.
6. Tighten the (inner) Hex Nut just enough to engage the notch. If this Hex Nut is too tight, it will restrict (up and down) Chuck-Spindle movement.
7. Loosen and screw the Hex Nuts (31) to the top of the Stop Rod (B12).

Troubleshooting

Problem	Possible Causes	Likely Solutions
Tool will not start.	<ol style="list-style-type: none"> 1. Cord not connected. 2. No power at outlet. 3. Internal damage or wear. 	<ol style="list-style-type: none"> 1. Check that cord is plugged in. 2. Check power at outlet. If outlet is unpowered, turn off tool and check circuit breaker. If breaker is tripped, make sure circuit is right capacity for tool and circuit has no other loads. 3. Have technician service tool.
Tool operates slowly.	Extension cord too long or wire size too small.	Eliminate use of extension cord. If an extension cord is needed, use shorter/heavier gauge cord. See <i>Extension Cords</i> in <i>GROUNDING</i> section.
Performance decreases over time.	<ol style="list-style-type: none"> 1. Accessory dull or damaged. 2. Carbon brushes worn or damaged. 	<ol style="list-style-type: none"> 1. Keep cutting accessories sharp. Replace as needed. 2. Have qualified technician replace brushes.
Excessive noise or rattling.	<ol style="list-style-type: none"> 1. Belt too loose (slipping) or too tight (bearing damage). 2. Spindle dry 3. Loose spindle pulley 4. Loose motor pulley 5. Internal damage or wear. 	<ol style="list-style-type: none"> 1. Properly tension belt. 2. Lubricate spindle 3. Check pulley nut 4. Tighten Set screws 5. Have technician service tool.
Overheating.	<ol style="list-style-type: none"> 1. Forcing machine to work too fast. 2. Accessory misaligned. 3. Accessory dull or damaged. 4. Blocked motor housing vents. 5. Motor being strained by long or small diameter extension cord. 	<ol style="list-style-type: none"> 1. Allow machine to work at its own rate. 2. Check and correct accessory to table alignment. 3. Keep cutting accessories sharp. Replace as needed. 4. Wear ANSI-approved safety goggles and NIOSH-approved dust mask/respirator while blowing dust out of motor using compressed air. 5. Eliminate use of extension cord. If an extension cord is needed, use one with the proper diameter for its length and load. See <i>Extension Cords</i> in <i>GROUNDING</i> section.
Drill bit burns or smokes	<ol style="list-style-type: none"> 1. Incorrect spindle speed 2. Dull drill bit 3. Drilling too slowly 4. Lacking lubrication 	<ol style="list-style-type: none"> 1. Change spindle speed 2. Replace with new bit 3. Drill faster 4. Lubricate cutting area
Drill bit wobbles	<ol style="list-style-type: none"> 1. Bent bit 2. Worn Spindle Bearings 3. Drill bit not in Chuck correctly 4. Chuck not properly installed 	<ol style="list-style-type: none"> 1. Replace drill bit 2. Replace spindle bearings 3. Reinstall drill bit 4. Reinstall Chuck and Arbor assembly
Feed Wheel returns slowly, or too fast	Tension Spring not in adjustment	Adjust Tension Spring.
Drill bit binds	<ol style="list-style-type: none"> 1. Workpiece pinching drill bit 2. Dull drill bit 3. Feed pressure too hard 4. Belts loose 	<ol style="list-style-type: none"> 1. Reposition workpiece, lubricate drill 2. Replace drill bit 3. Pull Feed Handle slowly. 4. Adjust motor and spindle belt tension



Follow all safety precautions whenever diagnosing or servicing the tool. Disconnect power supply before service.

PLEASE READ THE FOLLOWING CAREFULLY

THE MANUFACTURER AND/OR DISTRIBUTOR HAS PROVIDED THE PARTS LIST AND ASSEMBLY DIAGRAM IN THIS MANUAL AS A REFERENCE TOOL ONLY. NEITHER THE MANUFACTURER OR DISTRIBUTOR MAKES ANY REPRESENTATION OR WARRANTY OF ANY KIND TO THE BUYER THAT HE OR SHE IS QUALIFIED TO MAKE ANY REPAIRS TO THE PRODUCT, OR THAT HE OR SHE IS QUALIFIED TO REPLACE ANY PARTS OF THE PRODUCT. IN FACT, THE MANUFACTURER AND/OR DISTRIBUTOR EXPRESSLY STATES THAT ALL REPAIRS AND PARTS REPLACEMENTS SHOULD BE UNDERTAKEN BY CERTIFIED AND LICENSED TECHNICIANS, AND NOT BY THE BUYER. THE BUYER ASSUMES ALL RISK AND LIABILITY ARISING OUT OF HIS OR HER REPAIRS TO THE ORIGINAL PRODUCT OR REPLACEMENT PARTS THERETO, OR ARISING OUT OF HIS OR HER INSTALLATION OF REPLACEMENT PARTS THERETO.

PARTS LISTS AND DIAGRAMS

Head Assembly Parts List

Part	Description	Part	Description
1	Head w/ Roll Pin and Trim	21	Switch, Locking
2	Nut, Lock, M8x1.25-8	22	Screw, Self Tap. Pan Hd. M4x16-8
3	Washer, 5/16 x 11/16 x 1/16	23	Cover, Switch Plate
4	Screw, Hex, M8x1.25-25	24	Key, Switch
5	Pulley, Motor	25	Connector, Wire
6	Screw, Hex Soc. Set, M6x1.0-10	26	Seat, Spring
7	Motor	27	Retainer, Spring
8	Stop, Motor	28	Spring, Tension
9	Spring, Motor Stop	29	Cap, Spring
10	Knob, Motor Adjusting	30	Nut, Hex, 3/8-24
11	Screw, Hex Soc. Set, M8x1.25-8	31	Nut, Hex, M10x1.5
12	Knob	32	Pointer
13	Rod	33	Cord, Power
14	Shaft, Pinion	34	Wrench, Hex 4 mm
15	Nut, Hex, M8x1.25	35	Switch, Light
16	Screw, Flt. Sit. Set, M8x1.25	36	Screw, Pan Hd.
17	Lockwasher, Ext. 5mm	37	Box, Light
18	Screw, Pan Hd. M5x0.8-8	38	Nut, Hex, M12 x 1.25
19	Box, Switch w/ Depth Scale	39	Washer, Rubber
20	Screw, Pan Cr., M5x0.8-12	40	Light with Cover

Record Product's Serial Number Here: _____

Note: If product has no serial number, record month and year of purchase instead.

Note: Some parts are listed and shown for illustration purposes only, and are not available individually as replacement parts.

Head Assembly Diagram

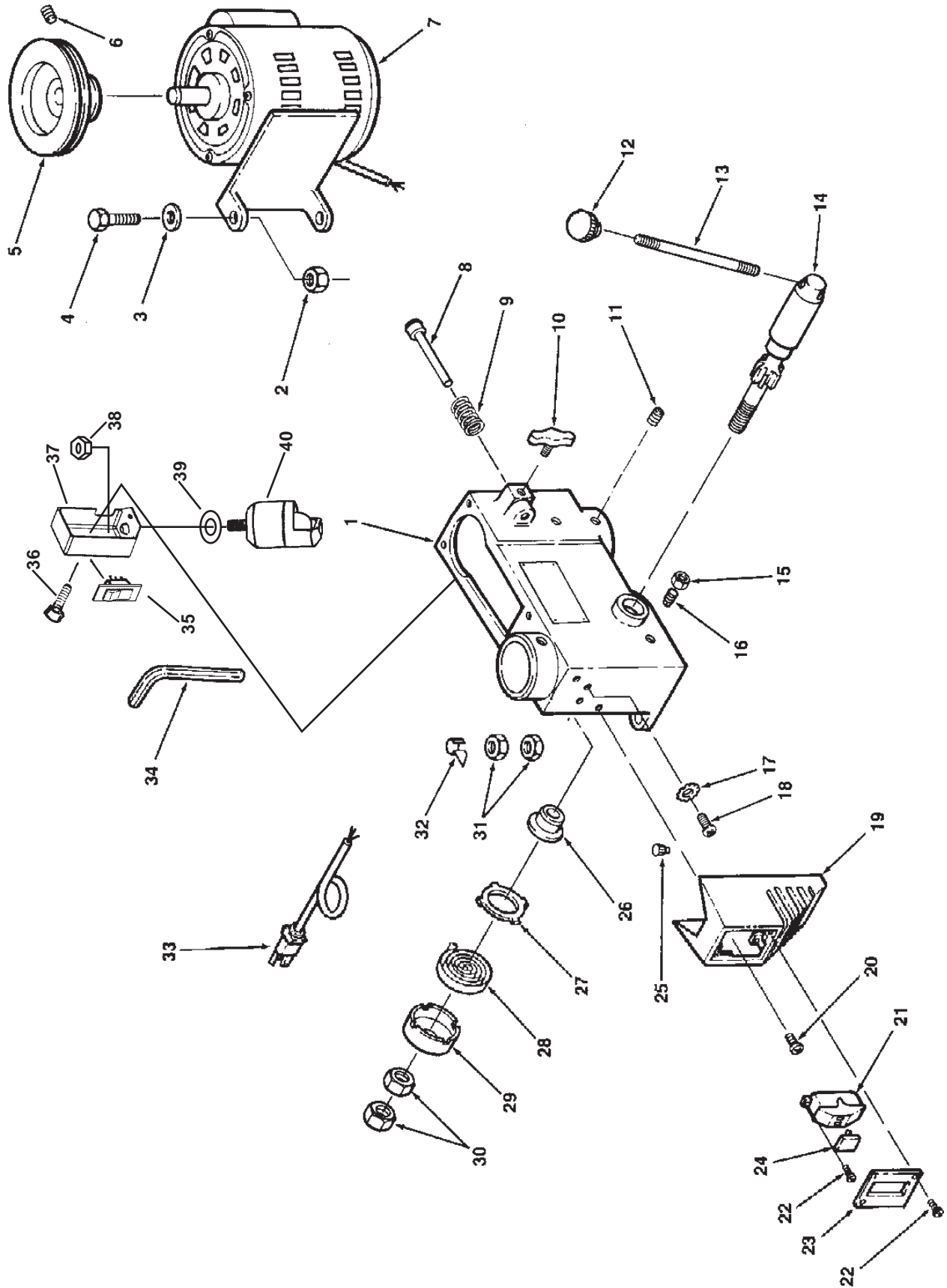

Parts List and Diagram A - Pulley and Spindle

Part	Description
A1	Bushing, Rubber
A2	Knob
A3	Screw, Pan Hd., M5x0.8-12
A4	Belt, V5, 5/16x26
A5	Guard with Labels
A6	Screw-washer Hd., M6x10-16
A7	Ring, Retaining
A8	Bearing, Ball, 17 mm
A9	Spacer
A10	Insert, Pulley
A11	Pulley, Spindle
A12	Nut, Pulley
A13	Clamp, Cord
A14	Screw, Pan Hd., M5x0.8-16
A15	Washer, Foam

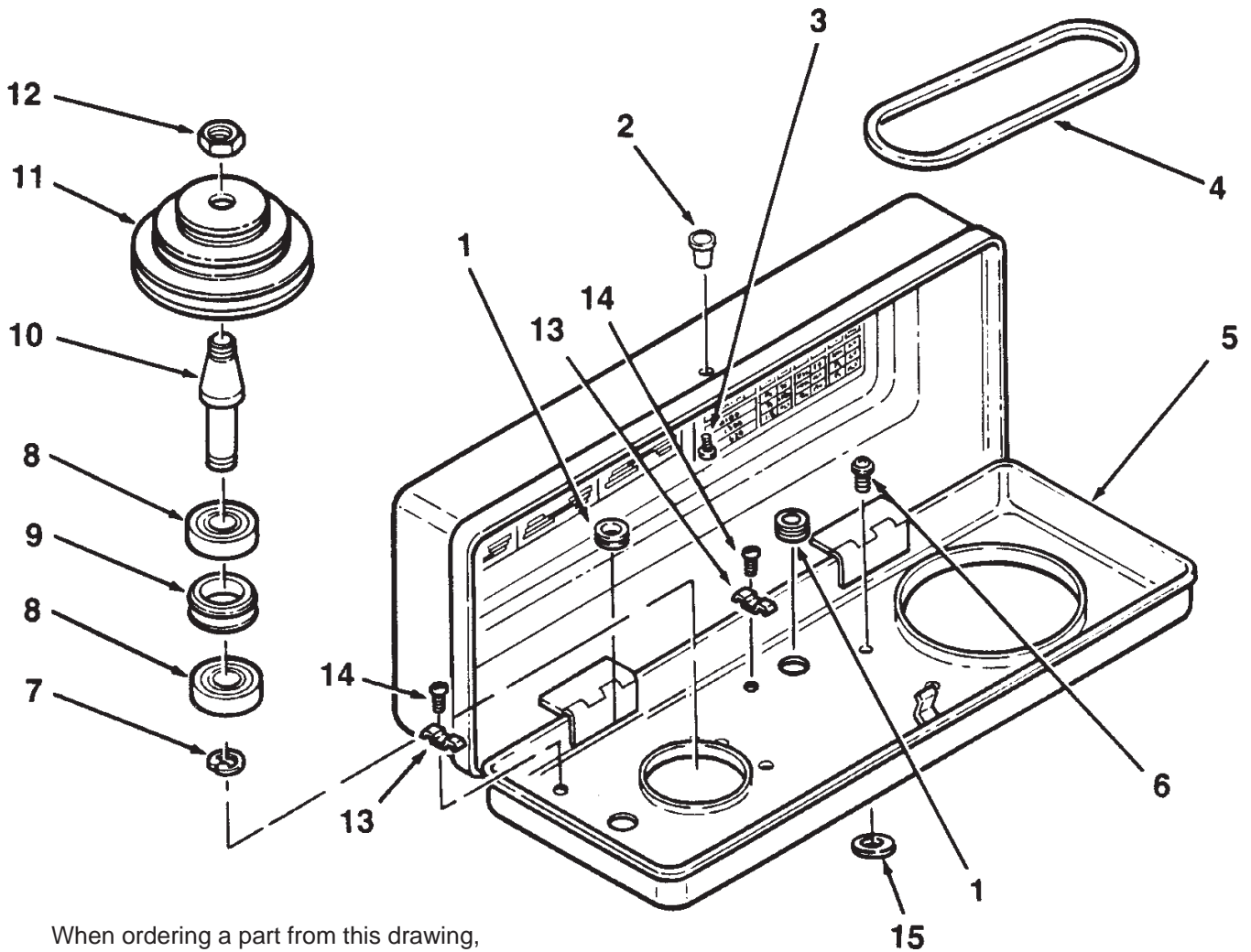

When ordering a part from this drawing, add an "A" prefix to the part number.

Parts List and Diagram B - Chuck and Spindle Shaft

Part	Description
B1	Gasket, Quill
B2	Bearing, Ball, 12 mm
B3	Tube, Quill
B4	Screw, Pan, M5x0.8-20
B5	Collar, Stop
B6	Ring, Retaining
B7	Shaft, Spindle
B8	Chuck
B10	Nut, Hex, M6x1.0
B11	Nut, Hex, M5x0.8
B12	Stop, Rod

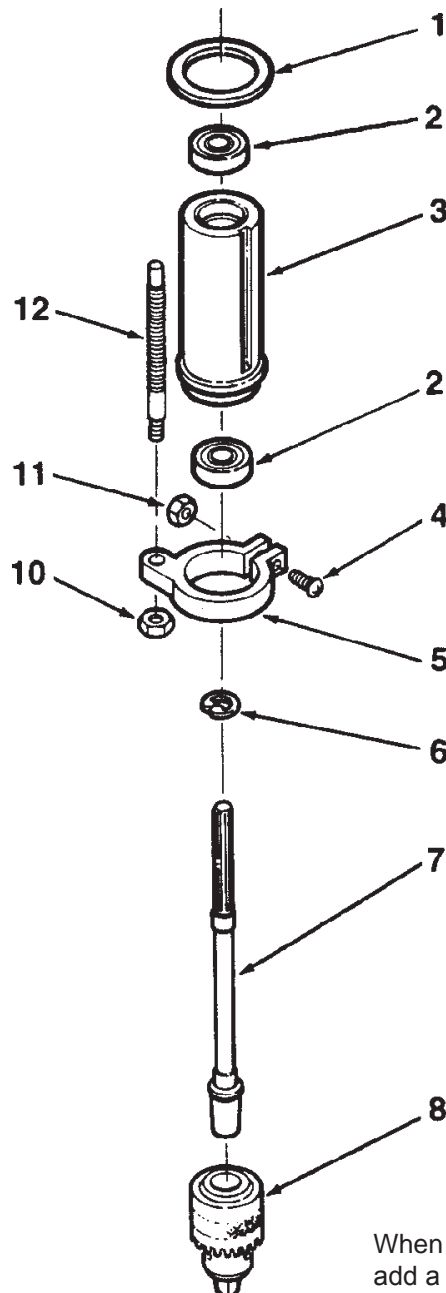

When ordering a part from this drawing, add a "B" prefix to the part number.

Parts List and Diagram C - Base and Table

Part	Description
C1	Support, Table with Scale
C2	Support, Lock Handle
C3	Tube, Support
C4	Base
C5	Screw, Hex Hd., M8x1.25-20
C6	Screw, Hex Hd., 1/2-12x7/8
C7	Table

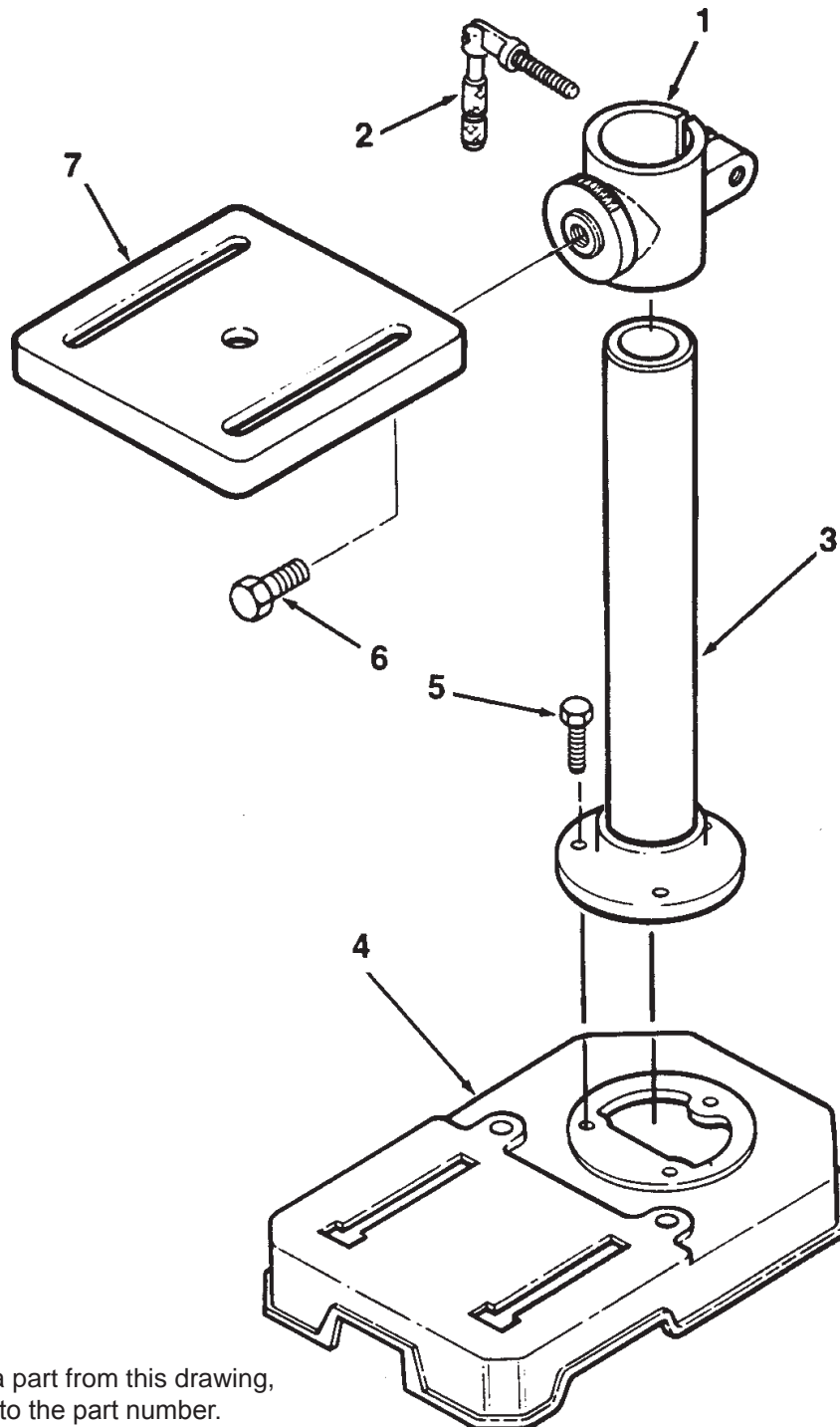

When ordering a part from this drawing, add a "C" prefix to the part number.

LIMITED 90 DAY WARRANTY

Harbor Freight Tools Co. makes every effort to assure that its products meet high quality and durability standards, and warrants to the original purchaser that this product is free from defects in materials and workmanship for the period of 90 days from the date of purchase. This warranty does not apply to damage due directly or indirectly, to misuse, abuse, negligence or accidents, repairs or alterations outside our facilities, criminal activity, improper installation, normal wear and tear, or to lack of maintenance. We shall in no event be liable for death, injuries to persons or property, or for incidental, contingent, special or consequential damages arising from the use of our product. Some states do not allow the exclusion or limitation of incidental or consequential damages, so the above limitation of exclusion may not apply to you. THIS WARRANTY IS EXPRESSLY IN LIEU OF ALL OTHER WARRANTIES, EXPRESS OR IMPLIED, INCLUDING THE WARRANTIES OF MERCHANTABILITY AND FITNESS.

To take advantage of this warranty, the product or part must be returned to us with transportation charges prepaid. Proof of purchase date and an explanation of the complaint must accompany the merchandise. If our inspection verifies the defect, we will either repair or replace the product at our election or we may elect to refund the purchase price if we cannot readily and quickly provide you with a replacement. We will return repaired products at our expense, but if we determine there is no defect, or that the defect resulted from causes not within the scope of our warranty, then you must bear the cost of returning the product.

This warranty gives you specific legal rights and you may also have other rights which vary from state to state.

**3491 Mission Oaks Blvd. • PO Box 6009
Camarillo, CA 93011 • (800) 444-3353**